

REQUEST FOR QUOTATION

Company name	
Contact person	
Address	
Telephone	
E-mail	

How to measure your wire mesh belt with single loop edge

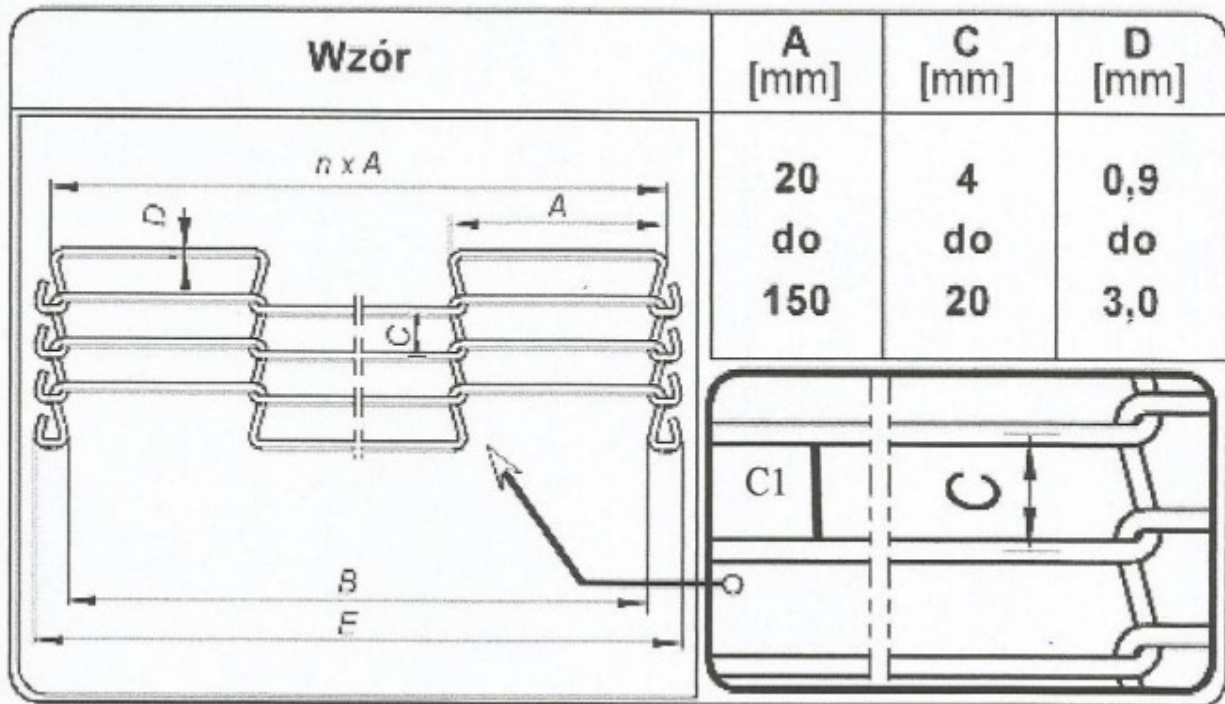

E	overall width (mm)	
L	length (mm)	
C	pitch (ctc distance wires in mm)	
C1	inside distance between wires	
D	wire diameter (mm)	
N	number of spaces (odd number)	
N x A	outside width without edge loops	
B	inside width without edge loops	
A	outside width of large mesh	